

THE **FLOW SCIENCES** BULK POWDER CONTAINMENT SERIES



- MOST EFFECTIVE AND EFFICIENT CONTAINMENT FOR BULK POWDER APPLICATIONS AND LARGE DRUM LOADING AND UNLOADING
- PREVENT LOSS OF CONTAINMENT WITH THE 3 MEMBRANE SAFETY SYSTEM FOR SECURING THE DRUM INTO THE INSIDE OF THE ENCLOSURE
- MANY EXHAUST / FILTER OPTIONS TO FIT SPECIFIC APPLICATIONS

SAFETY. The Bulk Powder series provides containment for large transfers of powder and pilot plant / manufacturing applications. FSI engineering controls are built in to prevent loss of containment. Third Party testing has proven containment on these units to below $1 \mu\text{g}/\text{m}^3$ based on process and quantity.

DESIGN. Designed similar to the top mount safety enclosures, this unit is able to effectively contain using airfoils and plenums to create laminar airflow across the work surface and reduce eddies and turbulence. The top mounted exhaust system with dual 4" HEPA filters can be recirculated into the lab or sent directly to house exhaust.

PHENOLIC BASE. The chemically resistant phenolic base is dished to maintain spills and protects the work surface from harmful chemicals.

DUAL HINGED FRONT DOORS. Front doors allow for easy equipment loading and unloading.

ACRYLIC WALLS. The clear acrylic walls are used for increased ambient light transmission

ADJUSTABLE HEIGHT TABLE. This enclosure has an optional adjustable height table for loading/unloading drums of various sizes. These tables also have improved ergonomics over fixed height tables.

STANDARD SIZES. The Bulk Powder series is available in 4, 5, 6, and 8 foot standard width options. Customs are available.

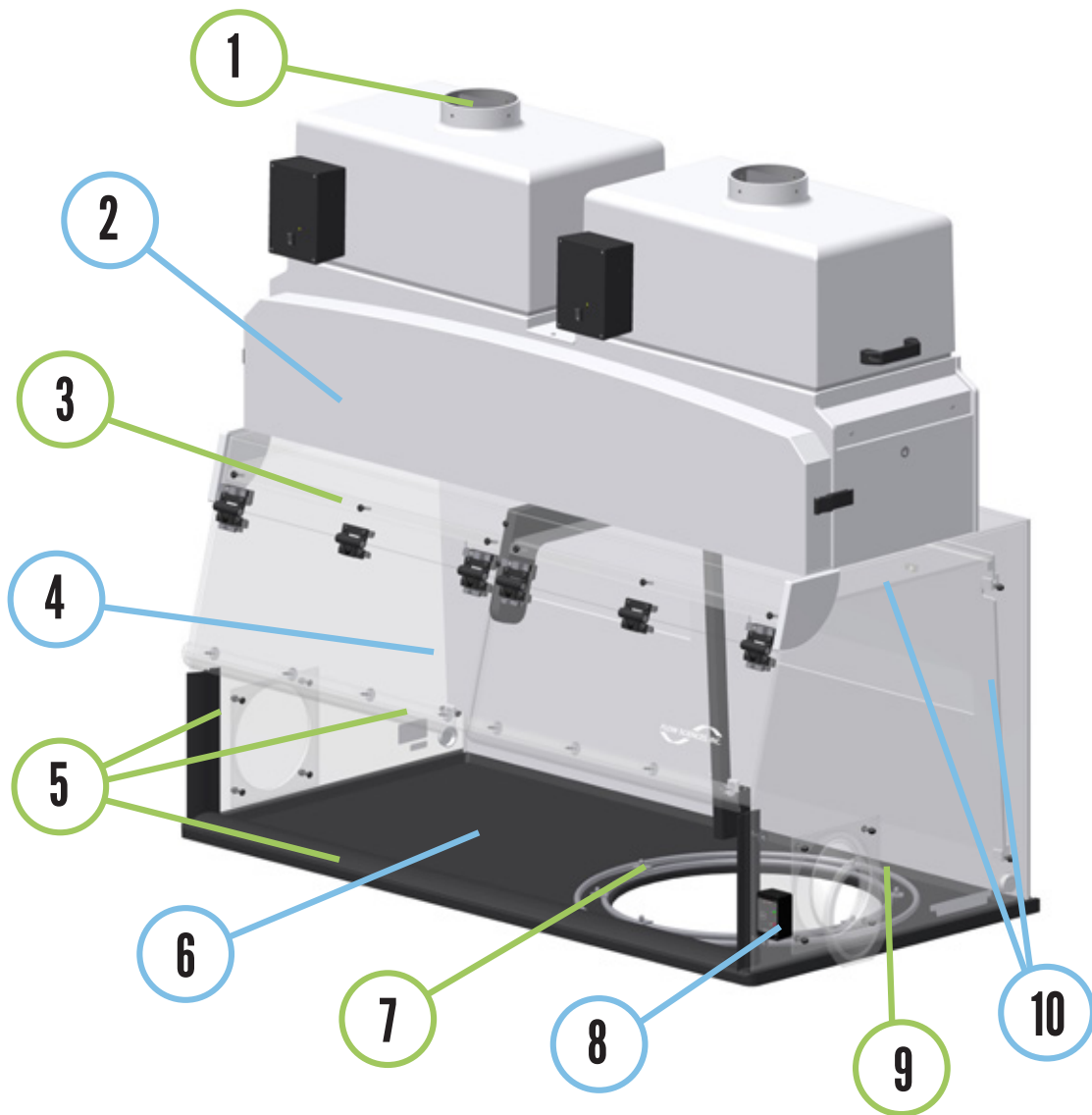

- 1 EXHAUST PORT** - 6" thimble connections to house system or can be recirculated back into the lab
- 2 BAG-IN / BAG-OUT** - HEPA change out system that allows for safe removal and replacement of the main 4" HEPA filter
- 3 OPTIONAL LED LIGHT** - LED lights available upon request
- 4 FRONT LIFT DOORS** - Hinged front doors that lift for easy loading or unloading of equipment
- 5 AIRFOILS** - Airfoils staged around the perimeter of the face opening stabilize the airflow, improve laminar airflow, and improve containment along the leading edge

- 6 DISHED BASE** - Dished phenolic base captures accidental liquid and powder spills
- 7 CUTOUT AND MEMBRANES** - Bulk Powder drum cutout with 3 membranes maintain a proper seal around drum for excellent containment
- 8 FS1650 ALARM** - FS1650 Face Velocity Alarm alerts the operator when airflow is compromised
- 9 WASTE PORT** - Waste port can be placed on either and/or both sides of the enclosure and is used to safely remove waste
- 10 PLENUMS** - Rear and Top Plenums are used to direct airflow and maintain containment at the face opening. These also prevent particles from possibly falling back onto the work surface if the fan is turned off

TOP MOUNT TECHNOLOGY

Flow Sciences' Top Mount Safety Enclosure with Bag-in / Bag-out Filtration is engineered to provide a safe, stable working environment in laboratory settings. The 30" deep base accommodates larger micro and analytical balances and the gentle, non-turbulent airflow maintains stable balance readouts and limits loss of materials. Internal plenums and mounted aerodynamic airfoils around the face opening ensure smooth, horizontal airflow pattern across the work surface. The bag-in / bag-out filter is designed for safe disposal and replacement of HEPA filter by a certified technician. In Flow Sciences' "Filter First" design, the fan is positioned to remain contaminant-free even when changing out the primary HEPA filter.

Enclosures may be configured to discharge to house exhaust or to re-circulate back into the lab. Units configured for recirculation are portable and can easily be moved when necessary. A secondary filter is located between the primary filter and the fan box (patent pending) making this the safest enclosure of its kind on the market. The non-loading secondary HEPA filter prevents any contaminants that might migrate upstream during Bag-in/Bag-out disposal from coming in contact with the fan unit and being discharged to house exhaust or re-circulating into the room.

Clean-up is made easy with quick, tool-free removal of internal top and rear plenums allowing access to all surfaces inside the work area for an easy wipe-down with diluted alcohol mixture while the exhaust unit is operating. Engineered with minimal crevices for superior clean-ability minimizing cross-contamination risks. The operation of the fan is exceptionally quiet providing a comfortable work environment. The front of the enclosure is angled for easy viewing while maintaining a safe, comfortable working position. The base of the unit is black for easy powder detection and dished for spill containment. Each system comes equipped with Face Velocity Alarm to alert the operator of velocities below a preset spread.



NO DETECTABLE VIBRATION

The Flow Sciences Top Mount Enclosure Series eliminates vibration. Through engineering controls and intuitive design, the vibration of the fan does not transfer to the work surface, allowing for accuracy in weighing and other sensitive applications.

CUSTOM ENCLOSURES

Flow Sciences has a team of engineers that will work with you to design and manufacture a custom containment solution for your specific application. After production, FSI tests these enclosures in our on-site laboratory, and we welcome 3rd party consultants for Factory Acceptance Testing.

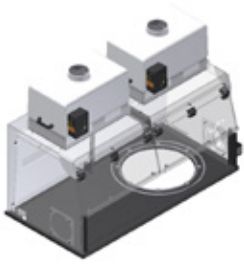

FAN / FILTER

- ★ **CIRCULATE INTO LAB OR CONNECT TO HOUSE EXHAUST**
- ★ **SINGLE 4" PLEATED HEPA FILTER**
- ★ **CLEAR ACRYLIC CONSTRUCTION**

The most common exhaust option for pharmaceutical compounding is our fan / filter option. With a 4" pleated HEPA filter and fan, this enclosure is ideal for working with APIs and many more applications. The top mount fan has a 6" exhaust port that allows for circulation into lab or connection to house exhaust. FSI has a bag-out filter procedure to replace this filter after its 3-5 year life span.

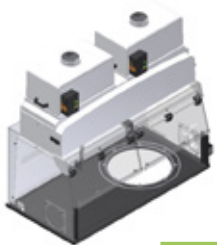

FAN / BIBO

- ★ **BAG-IN / BAG-OUT FILTER CHANGE**
- ★ **DUAL 4" PLEATED HEPA FILTERS**
- ★ **CIRCULATE INTO LAB OR CONNECT TO HOUSE EXHAUST**

The Bag-in / Bag-out (BIBO) filter change method is unique to Flow Sciences and we are very proud to provide dual HEPA filtration and ease of filter change. This system allows for circulation into the lab and also connection straight to house exhaust. The BIBO system allows for the filter to be changed in a clean environment where the saturated filter is not exposed to the lab environment.

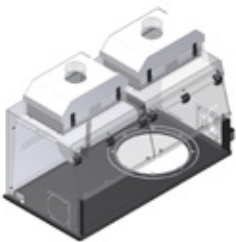

FILTER / NO FAN

- ★ **VENT DIRECTLY TO HOUSE EXHAUST**
- ★ **SINGLE 4" PLEATED HEPA FILTER**
- ★ **USE WITH EXPLOSION PROOF APPLICATIONS**

This enclosure is designed for applications that need to be filtered, but still be vented to house exhaust. Featuring a 4" HEPA filter and exhaust cap, a 6" exhaust port would be attached to existing house exhaust. This enclosure can also be used for explosion proof (XP) applications when connected to an xp fan.



NO FAN / NO FILTER

- ★ **VENT DIRECTLY TO HOUSE EXHAUST**
- ★ **USE FOR XP APPLICATIONS**
- ★ **CLEAR ACRYLIC CONSTRUCTION**

This exhaust option is the most similar to the original VBSE™ from Flow Sciences. With no fan and no filter, this enclosure is versatile and can be connected directly to house exhaust or to a remote fan/filter. Labs with upper cabinets could benefit from this enclosure as the total height is less than other top mount series options.

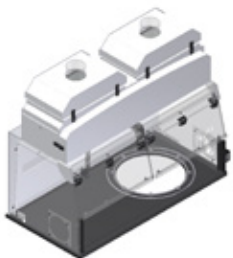

BIBO / NO FAN

- ★ **BAG-IN / BAG-OUT 4" PRIMARY PLEATED HEPA FILTER**
- ★ **SECONDARY (SAFETY) 4" PLEATED HEPA FILTER**
- ★ **VENT DIRECTLY TO HOUSE EXHAUST**

This exhaust option is engineered for applications that need dual HEPA filtration and also sent directly to house exhaust. The Bag-in / Bag-out (BIBO) filter change procedure includes dual 4" HEPA filters with a simple primary filter changeout method that never exposes the lab to the saturated filter. This enclosure can also be used for explosion proof (XP) applications.

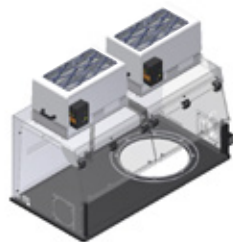

MESH FAN / FILTER

- ★ **RECIRCULATE INTO LAB**
- ★ **SINGLE 4" PLEATED HEPA FILTER**
- ★ **USE IN LOW CEILING APPLICATIONS**

Often times in a low ceiling situation, a focused exhaust port could deflect off of the ceiling and send air down across the face opening. To prevent this, Flow Sciences has mesh top fans that evenly distribute the exhausted air, thus preventing face opening shear. Equipped with a single 4" pleated HEPA filter, this exhaust option is ideal for recirculating back into the room.

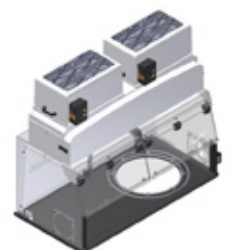

MESH FAN / BIBO

- ★ **RECIRCULATE INTO LAB**
- ★ **BAG-IN / BAG-OUT FILTER CHANGE**
- ★ **USE IN LOW CEILING APPLICATIONS**

This exhaust type uses the mesh fan that evenly distributes the exhaust air, but also includes the Bag-in / Bag-out filter change system. This unit has dual 4" pleated HEPA filters. Mesh fans only recirculate into the room.



Address
**654 Petrolia Road,
 Toronto, ON M3J 2W3**

Tel: (416) 736-6166
 Toll Free: (800) 387 3570
 Fax: (416) 736-9346
 E-mail: info@betatekinc.com

